

注：钢丝将两层丝网捆在圆筒上，端部点焊。

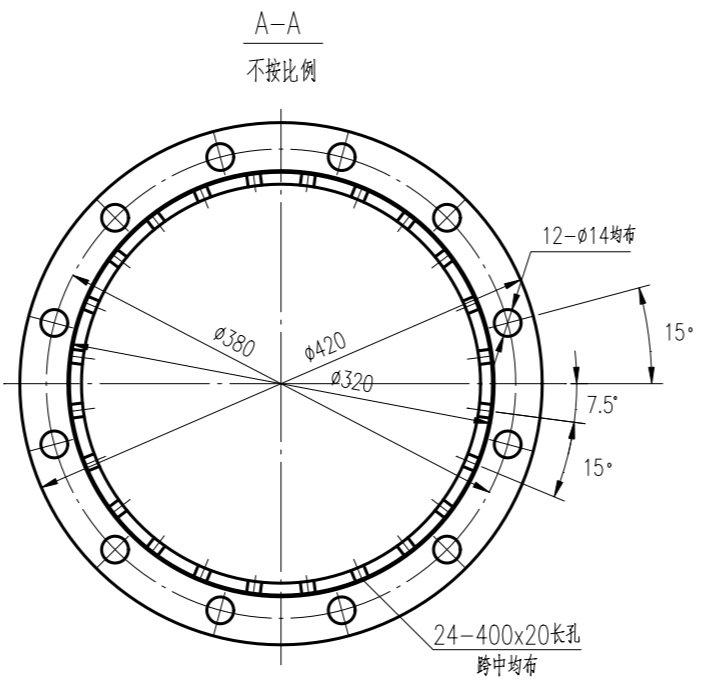
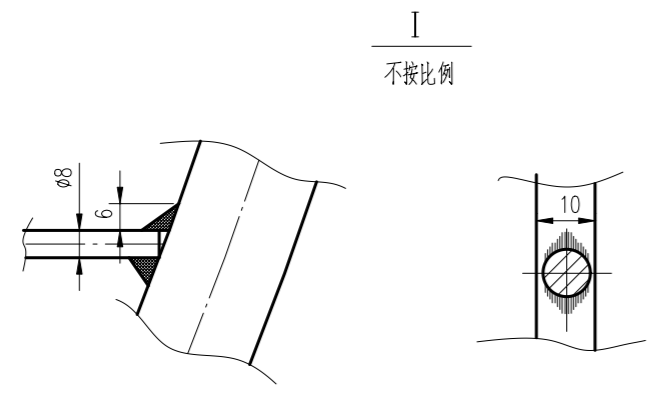

14	圆钢 φ8	09MnNiDR	10.5	
13	环形压条	09MnNiDR	22.7	
12	JB/T41-2000 螺母 M12	A2-70		
11	JB/T5780-2000 螺栓 M12x45	A2-70		
10	圆形板 φ400 δ=10	09MnNiDR	5.9	
9	筛板 100x50x10	09MnNiDR	0.4	1.6
8	JB/T4746-2002 支承封头EHA1400 δ=12	09MnNiDR	210	
7	卡环板 δ=10	09MnNiDR	8.3	
6	垫板 δ=10	09MnNiDR	8.2	
5	环板 φ420/φ320 δ=12	0Cr18Ni9	4.3	
4	GB/T5330-2003 丝网 GF3W1.00/0.56	2.5m ³ 0Cr18Ni9	6.35	
3	圆筒 φ320x10	0Cr18Ni9	4.1	H=500
2	钢丝 φ2.5	不锈钢		L≈3050
1	圆板 φ350 δ=8	0Cr18Ni9	6.1	

件号 No.	图号或标准号 DWG. OR STAND. No.	名称 DESCRIPTION	数量 QTY.	材料 MATERIAL	单重 UNIT WEIGHT(kg)	总重 TOTAL WEIGHT(kg)	备注 REMARKS
2							

江苏索普(集团)有限公司
60万吨/年醋酸造气工艺技术改造项目
甲醇装置
详细工程设计
04014-V15303A/B-02 2版

专业 设备 区域 - 比例 - 第 1 张 共 1 张